



北京世维通光通讯技术有限公司

Beijing SWT Optical Communication Technology Co., Ltd.

InGaAs PIN Photodiode

Type: PDS343-CSC

FEATURES:

- Planar semiconductor design and dielectric passivation.
- 3-pin coaxial streamline packaging. with SC connector.
- Superior noise and photoelectric performance.
- Hermetical packaging and 100% purge burn-in.
- Applied for optical fiber communication system, analog CATV application.

ELECTRO-OPTICAL CHARACTERISTICS(T=25):

PARAMETERS	SYMBOL	TEST CONDITIONS	MIN	TYP	MAX	UNIT
Wavelength			1000		1650	nm
Dark Current	I_D	$E_e=0, V_R =5V$		0.2	0.5	nA
Responsivity	R_e	$V_R =5V, \lambda =1310nm$	0.85	0.90		A/W
Responsivity	R_e	$V_R =5V, \lambda =1550nm$	0.90	0.95		A/W
Capacitance	C	$f=1MHz, case grounded, V_R=5V, E_e=0$		0.63	0.75	pF
Operating voltage	V_{opr}			-5	-15	V
Frequency Responsibility	BW	$V_R=5V, 50 \Omega$ load with lead length=6mm, case open	2			GHz

ABSOLUTE MAXIMUM RATINGS(T=25):

PARAMETERS	MIN	MAX	UNIT
Reverse Voltage		25	V
Input optical power		10	dBm
Reverse Current		5	mA
Forward Current		10	mA
Operating Temperature	-40	+85	
Storage Temperature	-40	+85	
Lead Solder Temperature		260	
Lead soldering duration		10	s

PRECAUTIONS:

- a ESD protection is imperative.
- b Please shorten the length of the devices leads as much as possible.

Address : 10th Floor, Tower C2, Dong ChangAn Street Dongcheng Diatric, Beijing

P.C. : 100738 Tel : 010-85180588 Fax : 010-85185617 <http://www.swt-oc.com>



北京世维通光通讯技术有限公司

Beijing SWT Optical Communication Technology Co., Ltd.

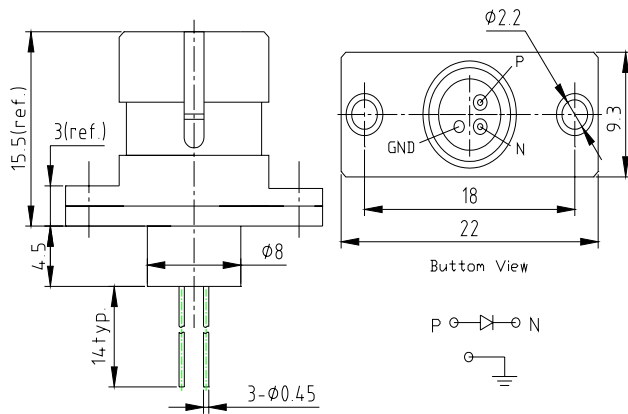

Package Dimensions

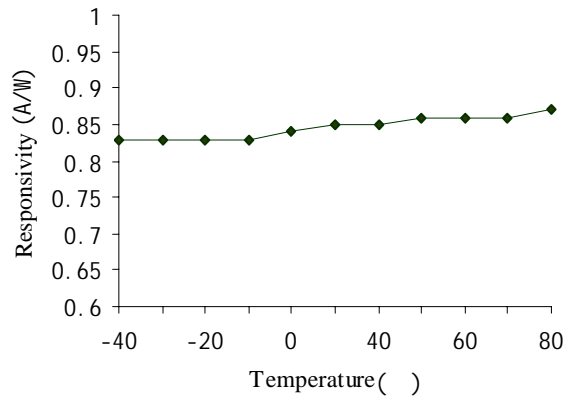

Responsivity-Temperature Curve

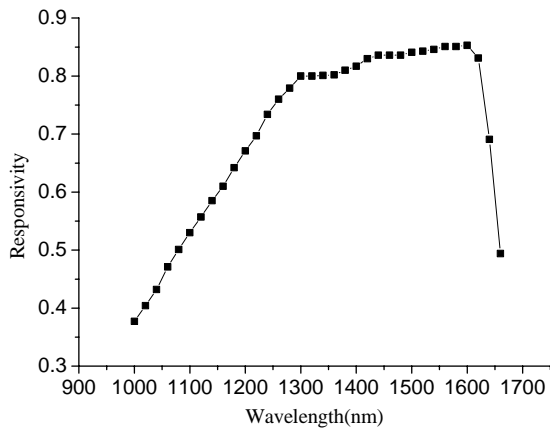

Spectrum Curve

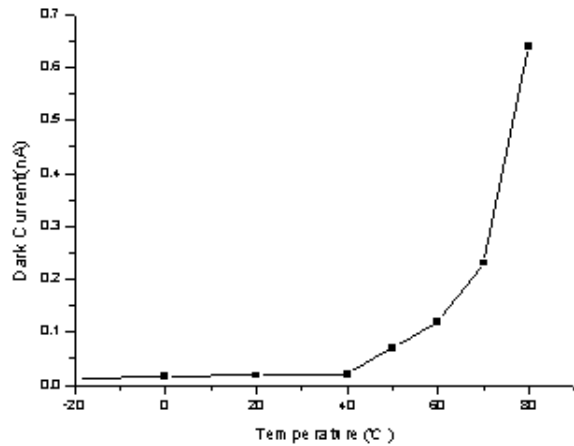

Dark Current-Temperature Curve

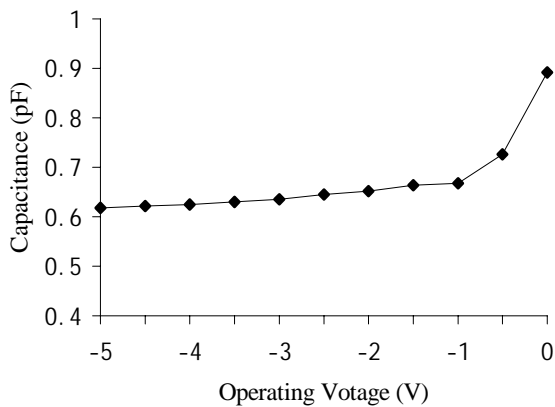

Capacitance-Voltage Curve

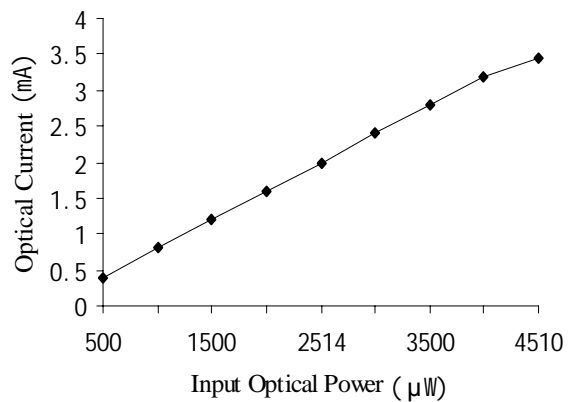

Current-Optical Power Curve